



# GRAM



SERIE

## K3X / K3iX / K3iX P

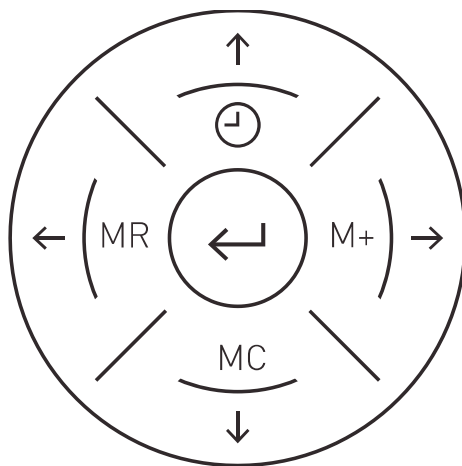

EN

CE

### OPERATION MANUAL





# INDEX

1.	KEYPAD AND LCD DISPLAY .....	5
2.	BEFORE USING THE SCALE .....	8
3.	ON / OFF.....	10
4.	INITIAL ZERO SETTING.....	10
5.	SOFTWARE VERSION IDENTIFICATION.....	11
6.	OPERATION .....	12
6.1.	USE OF THE SCALE.....	12
6.2.	TARE FUNCTION .....	13
6.4.	ZERO SETTING .....	15
6.5.	HIGH-RESOLUTION MODE.....	15
6.6.	H-L MODE (CONTROL OF UPPER/LOWER LIMITS) .....	16
6.7.	DOSING MODE .....	17
6.8.	PRINTING A SINGLE WEIGHING TICKET.....	18
6.9.	PRINTING A TOTALIZER TICKET .....	19
7.	CONFIGURATION OPTIONS MENU.....	20
8.	AUTO-OFF OPTION.....	23
9.	BACKLIGHTING THE DISPLAY.....	23
10.	SOUND WHEN PRESSING A KEY .....	24
11.	TARE OPTIONS.....	24
12.	DATA OUTPUT .....	25
12.1.	PR4/Q2 printer.....	26
12.2.	USB / USBFR .....	26
12.3.	Frame format PC0 .....	27
13.	TICKET PRINTING OPTIONS .....	30
14.	SCALE SETUP AND CALIBRATION .....	31
14.1.	Double range / interval configuration. ....	32
14.2.	Zero options menu.....	32
14.3.	Scale calibration .....	33
14.4.	Scale calibration procedure .....	33
16.3	Table of geographical adjustment values .....	35
15.	FILTERING SETTINGS .....	36
16.	DIGITAL OUTPUTS CONFIGURATION .....	37
17.	TECHNICAL SPECS.....	39
18.	CONNECTIONS.....	41
19.	ERROR MESSAGES.....	42
20.	NOTES.....	43



# 1. KEYPAD AND LCD DISPLAY

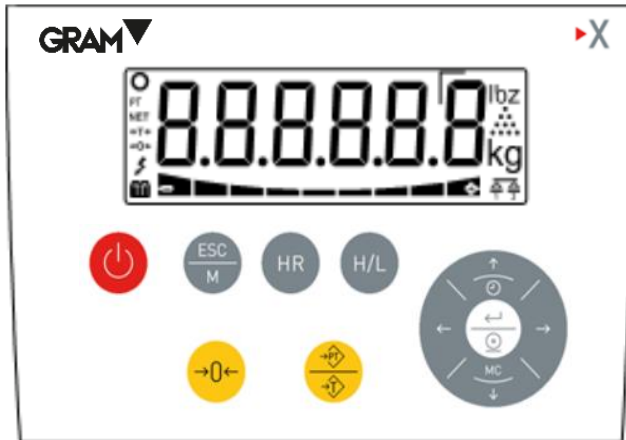

**Switches the device On / Off.** Press once to switch the scale on. Hold the key down for 2 seconds to switch off the scale.



**Esc / Menu.** It enters the menu settings mode. When already into the settings menu mode, escapes to the previous menu option or back to the weighing mode.



**High Resolution.** Activates the high-resolution mode. One more digit is added to the weight value for 4 seconds.



**High / Low limits:** activates / deactivates the checkweigher mode. ). Clicking twice will access the “H/L” mode settings.



**Zero button.** Sets the scale to zero.



**Tare .** A short pulse activates the tare function. This may be “measured tare” or “Pre-set tare” depending on the operating mode selected in the settings menu. If there is a pre-set tare in the memory and the platform is empty, pressing this button deactivates the tare. When clicking twice (double click) the tare mode alternates from “pre-set tare” to “measured tare”.

← → **Left / Right arrow.** Selects and edit a tare memory record.



**Print / Enter.** When in “Weighing mode” prints the current weighing data (simple ticket mode). When clicking twice, starts printing a totalisation ticket. When holding pressed for 2 seconds, ends the current totalisation ticket. When in menu settings mode, it confirms the selection/modification made.

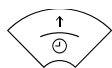













**Clock and Up Arrow.** In weighing mode, press to show the totalization amount. When keep pressed for 2 seconds will show the date and time. In menu mode, when editing a value, it increases the value (digit) of the display.



**MC and Down Arrow** When in weighing mode, keep pressed for 2 seconds to perform the “Clear” function: Cancel the tare, and resets the total weight. In menu mode, when editing a value, it decreases the value (digit) show on the display.

## LCD display symbols and readings:

	Displays the weight on the scale platform.
kg/g	Unit of measurement in which the weight is indicated.
	Stable weight reading: There is a weight on the platform that is not fluctuating. Intermittent or switched off to indicate that there is movement in the scale.
	Negative sign. Weight value may be negative if a tare is activated (when pre-set tare mode).
NET	Indicates net weight. The net weight is the real weight on the scale minus the tare. It is only displayed if a tare has been used.
	Tare activated. The reading flashes when "normal" tare mode has been activated. A "pre-set" tare is retained even after the weight is removed from the scale platform.
PT	Memory pre-set tare. The current tare is a value recorded into the indicator's memory; it could be not necessarily a measured value.
	Scale is set to zero (weigh is less than 1/4 division)
	Reading in high-resolution mode. It shows a division 10 times smaller than the one defined in the weighing scale range.
	Double range mode, when using the scale range 1.
	Double range mode, when using the scale range 2.
	The weight is below the lower limit. The 4 segments of this indicator are activated proportionally to the difference between the weight on the scale and the value of the lower limit. The thickest segment indicates that the weight is lower than the value set as the lower limit in a proportion of 100% or more.
	The weight is within the interval encompassed between the lower limit and the upper (high) limit.
	The weight is above the upper limit. The 4 segments of this indicator are activated proportionally to the difference between the weight on the scale and the value of the upper limit. The thickest segment indicates that the weight is higher than the value set as the upper limit in a proportion of 100% or more.
	Battery-operated. Shows the charge level of the battery when not connected to the mains,
	Plugged to the mains.

## 2. BEFORE USING THE SCALE

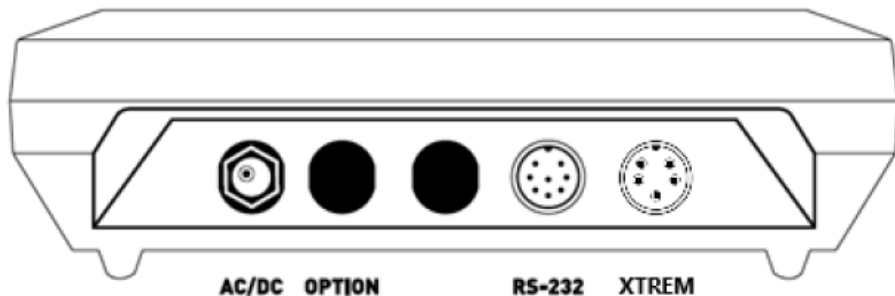

1. AC/DC adapter, output 12 Vdc – 1 A
2. Space allocated for additional options.
3. RS-232 data output.
4. Connector for the XTREM platform.

Attach the AC/DC power source to the unit and to a mains power outlet for charging the battery before its first use.

Attach the Xtrem platform cable to the Xtrem connector of the **K3X** terminal.

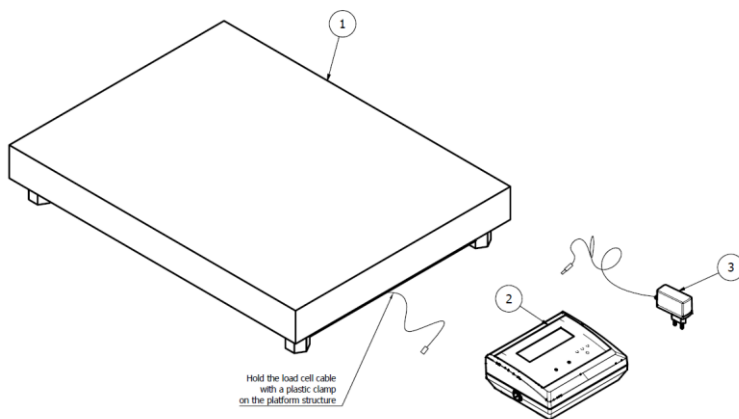



The load receptor platform should be placed on a flat surface free of any irregularities.

For the proper functioning of the instrument, the platform should be horizontally levelled. Before using the scale, check the bubble level mounted on the platform structure and adjust the levelling feet if necessary.

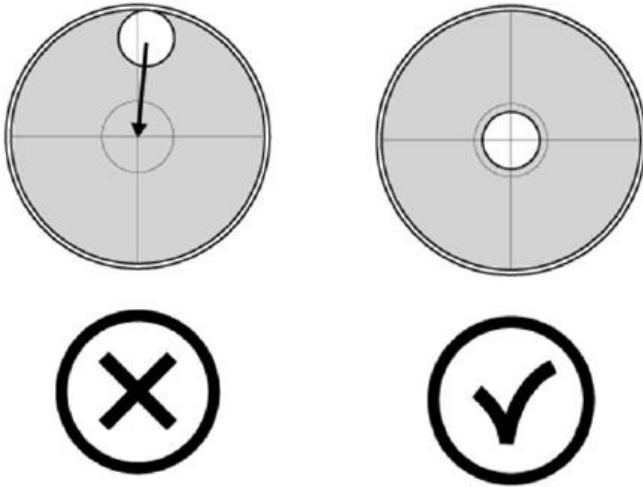

Both Xtrem module and the weight sensors mounted on the platform are sensitive to changes in ambient temperature. To achieve maximum accuracy, we recommend you keep the scale switched on for at least 30 minutes in its set-up site before using it.

### 3. ON / OFF



Press on the key. The display switches on and performs the following sequence:

1. All segments and symbols switch on for a second on the LCD display to verify that they are functioning properly.
2. It then shows the unit's firmware version code during one second.
3. Whilst connecting to the Xtrem scale will show a scrolling "--" sign.
4. Finally, will show the message **-00-** whilst performing the initial zero setting of the scale.

After the power-up sequence the scale is ready for use.

**To switch off the unit**, press on the same power-on key and keep it pressed for 2 seconds. An **OFF** message will appear to warn that the device will be switched off when the key is released.

### 4. INITIAL ZERO SETTING

When switching on the unit, it will automatically set to zero. This will be indicated in the display with the message **-00-**.

Automatically resetting to zero at the start requires the scale to remain stable for at least 5 seconds. For as long as the scale is moving, the **-00-** indication will be maintained for a maximum of 10 seconds.

If this time is exceeded without obtaining a stable reading, the display will show the weight on the scale.

If the weight on the load receptor is higher than 10% of the scale's maximum capacity, the scale will not set to zero, and the display will show the weight on the scale.

The **in 1-0** option in the configuration menu allows to activate or deactivates the initial zeroing as well as change the initial zero setting range.

## 5. SOFTWARE VERSION IDENTIFICATION

Firmware version is V 6.xxx, where “xxx” is referred to different functions which doesn’t affect legally relevant parameters.

**K3X** terminal display shows for 2” the embedded software version after power on.

Full information on **K3X** terminal module and Xtrem ADPD module can be show on the LCD display by following next steps:

Press  to enter the menu settings.

Press ← button until the display shows the option `INFO`, then press ↵

The following information will be shown:

K3X terminal embedded software version (V 6.xxx)

K3X terminal production reference (lot)

Related information on the Xtrem scale connected:

Serial number XXXXXX

Seal switch state as “UNPROT” / “PROT”

Software version as “S 3.007”

Weighing scale full capacity and verification interval.

Full information on the weighing scale configuration can be print using the menu settings option:

`MENU` → ... → `SCALE` ↵ → ... → `CAL` ↵ → ... → `PCAL` ↵

## 6. OPERATION

### 6.1. USE OF THE SCALE

Once the unit is switched on, the weight display will indicate that the scale:

- $\rightarrow 0 \leftarrow$  is set to zero, meaning that there is no load placed on the platform.
- $\bigcirc$  the reading is stable, that is to say, there is no external influencing factor (such as an air current or the vibration of a nearby engine) that may be producing significant disruption.



To find out the weight of any object within the scale's maximum range, place it on the load receptor platform: The zero reading and the stability reading disappears from the indicator; the weight value will change until the stability reading becomes visible again. The value indicated in the display is the result of the measurement.

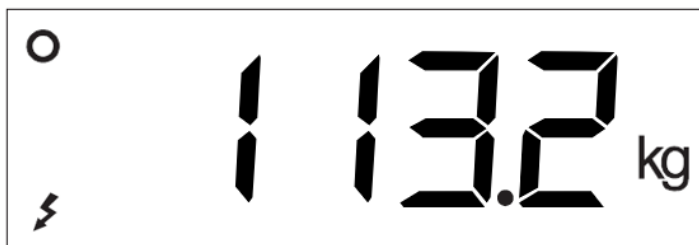

## 6.2. TARE FUNCTION



A short press on this key activates the tare function: The scale memorizes the weight currently on the load receptor and subtracts it from the total weight until the tare function is deactivated or cancelled.

The tare function only operates if the weight is stable. If the stability indicator is switched off, pressing this key has no effect.

Tare function can only be done when there is a weight higher than zero on the scale.

It can be “*Normal measured Tare*” or “*Pre-set Tare*” depending on the operating mode selected in the configuration menu (see option  $P-TR$ ).

- **Pre-set tare.** The tare remains after unload the load receptor. The  $>T<$  indication on the display stays constant, non-flashing. When the scale is emptied, the display shows the tare value with a negative sign. To cancel the tare, press on the tare button again after unloading the load receptor.
- **Normal measured tare.** The tare is automatically deactivated when the load receptor is empty. The  $>T<$  indicator is switched on intermittently in the LCD display.

Double press this key to switch the operating mode from “pre-set tare” to “normal measured tare”. The default operating mode for tare is “pre-set tare”, although this setting can be changed in the options menu (see option  $P-TR$ ).

To cancel the tare when a “pre-set” tare is active, with the load receptor empty, press the tare button again. The “clear” function (keep the MC button pressed for more than one second) also deactivates the tare. The zero-setting key also deactivates the tare.

### 6.3. MEMORY TARE RECORDING

It is possible to apply a tare previously memorized in the equipment. The indicator has up to 20 tare records, numbered from 1 to 20.

Use the ← and → keys to access this register and select one of the stored tares.

The display will show the message  $\text{t } \square \text{ t}$ ; press the → key to move on to register  $\text{t } \square \text{ t}$  and so on. Pressing the ← key returns to the previous tare memory.

Once you have selected the tare memory you wish to use, press the ↵ key, the display will show the associated tare value. Press and hold pressed the ↵ key for more than 1 second to apply the tare and the display returns to weight display mode.

To change the value associated with a tare value, follow the procedure below:

1. Use the ← y → keys to select the tare value you wish to modify and press the ↵ key.
2. The display shows the tare value associated with the selected register.
3. Enter the desired value using the arrow keys ← → to move to the next digit and the keys ↑↓ to modify the value of each digit.
4. Hold pressed the key ↵ for more than 1 second to validate the display content and store it in the indicator memory.

When a memorized tare is used, the display shows the **PT** ("preset tare") reading.

To cancel the tare, with the scale empty, press the tare button again. The "clear" function (press and hold the MC button) also disables the tare. The zero-setting key also disables the tare.

## 6.4. ZERO SETTING



A short press on this key sets the scale to zero. The scale is deemed to be “set to zero” when the weight on the load receptor is lower than  $\frac{1}{4}$  of division.

While the scale is “set to zero”, the reading  $\rightarrow 0 \leftarrow$  is shown in the display.

When the scale is set to zero the automatic “zero tracking” device is in operation. This function automatically sets to zero when variations of less than  $\frac{1}{4}$  division occur if they do not add up to more than  $\frac{1}{4}$  division during one second. This function can be deactivated in the  $\square - \text{E} - \text{R} - \text{R}$  option of the configuration menu.

Pressing on the zero key also deactivates the tare if it happens to be activated.

The zeroing of the scale is limited to 4% of its maximum capacity. Pressing the zero-setting button will not take effect when this margin is exceeded.

## 6.5. HIGH-RESOLUTION MODE



When pressing HR key, the scale’s resolution is enlarged by x10, allowing the weight to be viewed with a 10-times-smaller division for 4 seconds.

An additional digit appears in the weight display, and the decimal point is shifted to the left by one position. This additional digit is indicated with a straight angle in its top left corner:

*1 Example for a scale with a 1-kg division in normal mode and in high-resolution mode*

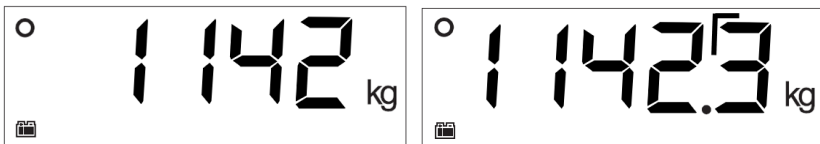

## 6.6. H-L MODE (CONTROL OF UPPER/LOWER LIMITS)



Activates or deactivates the upper and lower limit control mode. For an instant, the display shows the **H-L ON** message to indicate that it has been activated, or the **H-L OFF** message to indicate that it has been deactivated.

When the limit control is activated, a reading lights up in the bottom part of the LCD display to signal whether the net weight on the plate is lower than the **LOW** value or higher than the **HIGH** value. When the weight lies between the two values, a sign appears indicating that the weight is in the interval defined by the lower limit and the upper limit.

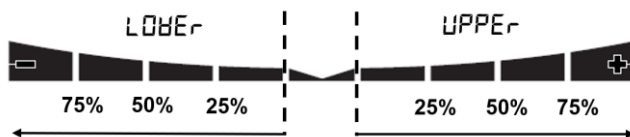

The colour of the display's backlighting changes to red when the weight is outside the interval defined by the upper and lower limit, and changes to green when the weight is within said interval.

The 4 segments of this reading are activated proportionally to the difference between the net weight on the scale and the value of the lower or upper limit. The thicker segment indicates that the weight is below the value set as the limit in a proportion of 100% or more.

Double-press on the H-L key to access the configuration and change the lower and upper limits. The possible options are:

**LOW**

Value for the lower limit, including the decimal part.

**HIGH**

Value for the upper limit, including the decimal part.

**ACT U**

Yes / No: Activating the limit control when switching on the unit.



## 6.7. DOSING MODE

The dosing mode is activated and configured by accessing the options menu in the  **UNIT** section (see section 16 in this manual).



Pressing the tare key initiates the dosing cycle, closing the K1 and K3 relay contacts. The display changes to blue to indicate that the dosing cycle has been initiated.

Upon reaching the weight established for **SPEED 1** (coarse flow), contact K1 is opened, and the display colour changes to indicate that the fine flow is in operation.

Upon reaching the weight set point established for **SPEED 2** (fine flow), contact K3 is opened and contact K2 is closed to indicate that the dosing cycle has finished. The light of the LCD display changes to green to indicate that the dosing cycle has finished.

Relay K2 (signalling the end of the dosing cycle) stays closed until the weight is removed from the scale. It is not possible to initiate a new dosing cycle if the cycle end outlet (K2 relay contact) stays closed.

To stop and pause a dosing cycle being run, press on the “tare” key. This action will open the K1 and K3 relay contacts, halting the dosing until the tare key is pressed again.

To stop and cancel a dosing cycle being run, hold pressed for 2 seconds the MC key .

## 6.8. PRINTING A SINGLE WEIGHING TICKET



Pressing this key when in “weighing mode”, will print the current weighing information (single weighing ticket).

The print key will only be effective if the weight on the scale is stable (the stability indicator is switched on).

A short press on this key will print a ticket with the following information: date and time, the Xtrem scale identification, the ticket’s serial number, gross weight, tare, and net weight (just the weight when not using the tare function).



*1 Weighing ticket in “weighing mode”*

Additionally, you can print a 3-line header and a footer line with constant information.

This gross/tare/net ticket is only possible provided no totalisation ticket has been initiated, which has a different format.

## 6.9. PRINTING A TOTALIZER TICKET



Double press the print key will starts printing a totalizer ticket.  
When holding pressed for 2 seconds, prints the current total and exits the totalizer function.

The print key will only be effective if the weight on the scale is stable (the stability indicator is on).

To initiate a totalizer ticket, weigh the first object to be added to the total and double press the print key. The weight is printed and added to the accumulated total. Repeat this operation to aggregate and print each one of the subsequent weights to the ticket.

At the end of each weighing sum, the total accumulated sum appears in the display for 2 seconds.

To complete the ticket and print the line for the total, press and hold pressed for 2 seconds the print key. You can view the total at any time before completing the ticket by pressing on the ↑ key.

GRAM PRECISION			
Travessia Industrial 11			
L'Hospitalet de Llobregat			
29/04/21 16:27:48 Num.		112	
Xtrem s/n 370275			
001	16:27:48	NC	0.021 kg
002	16:27:57		0.042 kg
003	16:28:01		0.052 kg
004	16:28:08		0.020 kg
005	16:28:16	NC	0.010 kg
-----			
Total			0.145 kg
<a href="https://gram-group.com">https://gram-group.com</a>			

2 Example of totalization ticket.

## 7. CONFIGURATION OPTIONS MENU



To access the configuration options menu, press the “M” key. The display shows the **MENU** message for 1 second to indicate that from then on, the indicator will start showing the different setting options. In “menu mode”, use the arrow keys to change to the next option or change the value of one digit in the display when editing the value of a parameter.



Returns to the menu’s previous level without making any change.

When in the main menu, exit the menu mode and return to normal operation mode (weighing mode).



Moves to the next menu option in the “left” direction or changes between the different setting values available.



Moves to the next level of the options menu or shows the current value of an option. When changing the selected value for an option (using the ← and → keys), pressing this key will validate the change. In “edition” mode (manual input of a parameter value), one short press moves you to the next digit on the display. A long hold or a double press validates the entered value



Moves to the next menu option (right arrow key) or to the previous menu option (left arrow key) or changes between the different setting values available.

To change the value of one digit in the display when inputting a data item.

## The table below summarizes the different configuration options:

MEW								
A-OFF	OFF •	ON	1h	1h30				Automatic shutdown options
BL-ON	OFF	On	Auto •					Backlight options
bEEP	OFF	On •						Beep ON/OFF
tAR	P-tAr	n-tAr						Tare mode : Pre-set / normal tare
rS232	bAudr	9600 •	19200	38400	57600	115200		RS-232 data output baud rate
	S-Mod2	Pr int •	Cont	StAb	nonE			RS-232 data output : data send mode
	For n 2	Pr 4 •	E26	PC-0	USB	USBFr	RE	RS-232 data output : peripheral connected
ticAt	tIME	YEAR	Month	DAY	hour	minute		Date and time settings
	SER-n	00000						Ticket / receipt serial number
	A-Cut	OFF •	On					Auto-cut paper
	dEC-S	COMMA	Dot					Decimal separator
SCALE	Unit	g	g9					Scale unit
	MAX	00000						Maximum capacity (Max <sub>1</sub> when 2 ranges or 2 intervals)
	dIU	1 •	2	5	10	20	50	Scale interval (e <sub>1</sub> )
	dEC	dP 0 •	dP 1	dP 2	dP 3	dP 4		Decimal position
	2-rAn	r-Mod	n0 •	2-rAn0	2-int			Activate double range or double interval mode
	MAX2	00000						Max <sub>2</sub> when 2 ranges / intervals
	dIU2	1 •	2	5	10	20	50	e <sub>2</sub> when double range / interval
	zEr0	In I-0	YES •	n0				Auto-zero at start
		125r	00000					Initial zero setting range in % of Max
	z-tAr	On •	OFF					Zero tracking on/off
	z-t-rn0	0.25E	0.50E	1.00E	1.50E			Zero tracking range
	dISP	BE 9h	F-ctt	F-ctt				Data to show in weighing mode
	CAL	CAL 1b						Calibration process
	G-COR	G-COR	On •	OFF				Automatic correction for gravity force effect
		GEO	000	...	031			Location code for g force correction
	OFFSet	00000						AD/C counts at zero
	SPAn	00000						Conversion factor from AD/C counts to scale units
	PrCAL							Prints settings

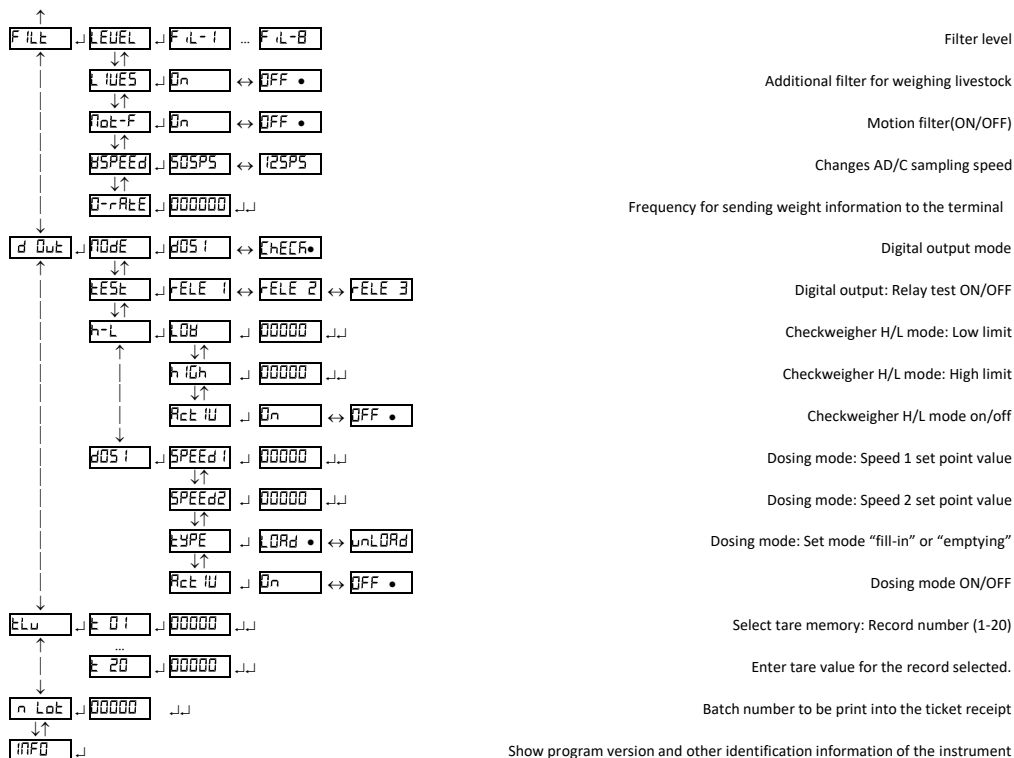

NOTE: The • symbol in the above table shows the default value for each configuration parameter.

## 8. AUTO-OFF OPTION A-OFF

This option programs the device's automatic switch-off after a time on idle (not being used). The device is understood to be on idle if there is no variation in the weight indication, and no key is pressed.

The possible options are the following:

OFF ●

The device always remains switched on. Option selected at source.

30n

The device switches off automatically after 30 minutes of inactivity.

1h

The device switches off automatically after 1 hour of inactivity.

1h30n

The device switches off automatically after 1:30 hours of inactivity.

## 9. BACKLIGHTING THE DISPLAY bL-On

This option controls the performance of the LCD display backlight. Together with the **Auto-off** option, it reduces power consumption and extends battery life. The unit is deemed to be inactive if the scale is set to zero and there are no changes in the weight reading and no key is pressed. The possible options are the following:

Auto ●

The *backlight* switches off automatically after 10 seconds of inactivity. This is the option selected at source.

OFF

The *backlight* is always switched off.

On

The *backlight* is always switched on.

## 10. SOUND WHEN PRESSING A KEY

**bEEP**

This function activates (“On”) or deactivates (“Off”) the emission of a sound when one of the keypad buttons is pressed.

The factory setting for this option is “On”.

## 11. TARE OPTIONS

**tArE**

The possible options are:

**P-tAr**

Pre-set tare: The tare will be kept until the tare key is pressed again with an empty load receptor platform. It is the default option.

**n-tAr**

Normal measured tare. The tare is automatically deactivated when the plate is emptied. The >T< indicator is switched on intermittently in the LCD display.



## 12. DATA OUTPUT r5232

There are several peripherals that can be attached to the **K3X** terminal for output the weighing information using the RS-232 serial output connector. The different settings on the r5232 menu allows to configure the RS232 output.

bAudr Select the baud rate at which the peripheral will be connected. The possible options are: 9600 bauds, 19200 bauds, 38400 bauds, o 57600 bauds. The transmission format for each byte is 8 bits, without parity bit, 1 stop bit (“8,n,1”) and it is not configurable.

5-Mod2 Mode in which the data transmission will be made:

- Pr Int ● • When pressing the print key.
- Cont • Continuously, at a rate of 5 frames sent per second.
- StAh • Automatically every time there is a new stable weight on the scale.
- nnnF • The serial port is deactivated.

ForA 2 Format of data frame to be transmitted. Select the peripheral to be connected from the following options.

- Pr4 ● Connection to model **PR4** printer. A ticket is sent in a format for this printer model.
- PC-0 For connecting to **PC with Virtual Key application**.
- USB Data in a format for the **GRAM USB** adapter cable.
- USBFr Frame data in a format for the **GRAM USBFR** adapter cable (emulating “AZERTY” keypad).
- Q2 Connection to **Q2** label printer. A ticket is sent in a format for this printer model.

### 12.1. PR4/Q2 printer

When selecting this option, the scale will send weight information in a ticket print format for GRAM PR4 thermal printer or Q2 label printer.

The ticket can have up to 3 header lines and 1 footer line. The header and footer content is programmable by the user.

The options for configuring this document are in the **FILE** section of the main menu.

### 12.2. USB / USBFR

Format compatible with the GRAM USB adapter for PC-type computer with Microsoft Windows operative system.

From the PC's point of view, the GRAM USB adapter is a keyboard emulation that transforms the information transmitted by K3X terminal into a keyboard input.

When using a French "AZERTY" keypad, select the USBFR format.

### 12.3. Frame format PC0

The indicator sends the following byte frames (always 14 bytes in length).

0	1	2	3	4	5	6	7	8	9	10	11	12	13
02h	69h	20h	20h	20h	30h	2Eh	30h	30h	30h	6Bh	67h	0Dh	03h
STX	'I'	spc	spc	spc	0	.	0	0	0	k	g	CR	ETX

0 Start of text.

1 Status (tare, zero, net, stable, unstable).

2 Sign (blank space if value is positive, or '-' if negative).

3..9 Numerical value (ASCII) of the weight shown on the LCD display, including the decimal point.

10..11 Measurement unit: 'g', 'kg', 'oz', 'lb'.

12 Carriage return.

13 End of text.

The status byte is built from the binary values of the display indications (tare, zero, gross/net and stability). 20h is added to the result to ensure that the result is printable.

**Bit 0 (01h)** The transmitted value is the gross weight.

**Bit 1 (02h)** A tare is set.

**Bit 2** Not used, always 0.

**Bit 3 (08h)** The indicator is set to zero.

**Bit 4** Not used, always 0.

**Bit 5** Not used, always 0.

**Bit 6 (40h)** The weight is stable.

**Bit 7** Not used, always 0.

Bit 7	Bit 6	Bit 5	Bit 4	Bit 3	Bit 2	Bit 1	Bit 0
N/A	Stability	N/A	N/A	Zero	N/A	Tare	B / W

Examples:

The status byte is **61h** ('a')

$$61h - 20h = 41h \rightarrow$$

Bit 7	Bit 6 (stable)	Bit 5	Bit 4	Bit 3 (no zero)	Bit 2	Bit 1 (Tare off)	Bit 0 (Gross)
0	1	0	0	0	0	0	1

The status byte is **69h** ('i')

$$69h - 20h = 49h \rightarrow$$

Bit 7	Bit 6 (stable)	Bit 5	Bit 4	Bit 3 (zero)	Bit 2	Bit 1 (Tare off)	Bit 0 (Gross)
0	1	0	0	1	0	0	1

The status byte is **62h** ('b')

$$62h - 20h = 42h \rightarrow$$

Bit 7	Bit 6 (stable)	Bit 5	Bit 4	Bit 3 (no zero)	Bit 2	Bit 1 (Tare on)	Bit 0 (Net)
0	1	0	0	0	0	1	0

The status byte is **63h** ('c')

$$63h - 20h = 43h \rightarrow$$

Bit 7	Bit 6 (stable)	Bit 5	Bit 4	Bit 3 (no zero)	Bit 2	Bit 1 (Tare on)	Bit 0 (Gross)
0	1	0	0	0	0	1	1

The status byte is **6Ah** ('j')

**6Ah – 20h = 4Ah** →

Bit 7	Bit 6 (stable)	Bit 5	Bit 4	Bit 3 (zero)	Bit 2	Bit 1 (Tare on)	Bit 0 (Net)
0	1	0	0	1	0	1	0

The status byte is **6Bh** ('k')

**6Ah – 20h = 4Ah** →

Bit 7	Bit 6 (stable)	Bit 5	Bit 4	Bit 3 (zero)	Bit 2	Bit 1 (Tare on)	Bit 0 (Gross)
0	1	0	0	1	0	1	1

### 13. TICKET PRINTING OPTIONS

ⓧ ⓧⓧⓧ

This menu has various options for configuring the information that appears printed in the tickets generated by the **K3X** terminal.

ⓧ ⓧⓧⓧ

Setting the time on the scale's internal clock.

ⓧ ⓧⓧⓧⓧ

Value of the next ticket number to be printed. It is automatically increased with each print, whether it is a single ticket or a ticket with accumulated total.

ⓧ ⓧⓧⓧ

Automatic paper cutting ON/OFF. This function is only possible with ESC/Pos printers equipped with paper cutting device.

ⓧ ⓧⓧⓧ-5

Decimal separator to be used in data output.

Programming the ticket header and footer is not performed via the scale's keypad but via the RS-232 serial port. In the downloads zone of our website a program for PC is available with Microsoft Windows operative system for performing this function.

## 14. SCALE SETUP AND CALIBRATION

SCALE

At the **SCALE** menu you view and configure the settings needed to define and adjust the measurement scale of the instrument.



Access to these configuration options is reserved for technical personnel and is protected by a keyword to avoid accidental changes that would cause the instrument to malfunction. When trying to enter the **SCALE** menu, the terminal will prompt for a password. Enter pin “1009” to access the **SCALE** configuration.



When the weighing scale has been sealed to meet legal regulations, K3X terminal will not allow changes on most of these settings and will show the message **PRD** when trying to modify them.



The Xtrem unit records the date and time of the last modification in any of these parameters. Modifying these parameters may imply the loss of the equipment warranty.

unit

Measurement unit: g, kg

MAX

Maximum capacity (Max<sub>1</sub> when 2 ranges or 2 intervals). Enter the value, including the decimal digits.

div

Division: Scale interval (e<sub>1</sub> when 2 ranges); the smallest increment that the instrument can measure. Possible values are 1, 2, 5, 10, 20 or 50.

dEC

Position of decimal point.

2-rAn

Configuration menu for double range or double interval instrument.

ZEro

Configuration menu for the instrument's options associated to the automatic initial zero setting.

dISP

Test mode that allows to display the load cell signal instead the weight value. The display will show A/D converter counts.

CAL

Scale calibration options.

### 14.1. Double range / interval configuration.

2-rAn

Xtrem scale can be configured as a 2-ranges or 2-interval instrument using the settings on the 2-rAn menu.

r-Mod

Select the function mode: r0 (the scale will work as a single range instrument), 2-rAn9 (the scale will work as a 2 ranges instrument), 2 Int (the scale will work as a 2 interval instrument).

Max2

Second range / interval maximum capacity Max<sub>2</sub>.

d 102

Division for the second range / interval: e<sub>2</sub> scale interval; Possible values are 1, 2, 5, 10, 20 or 50

### 14.2. Zero options menu

2E-0

Configuration settings for the automatic zero setting of the scale after power on and the scale zero-tracking device.

In I-0

Activate / deactivate the initial zero setting feature. When select YES, the indication is automatically set to zero when the weighing instrument is switched on, before any weighing. This feature is activated as default factory setting, select r0 to deactivate the initial zero setting of the scale.

125r

Initial Zero Setting Range: Enter the maximum range for the initial zero setting of the scale as a percent of the maximum capacity.

0-trA

Zero-tracking device on / off. As factory default is set to ON.

2t-rn0

Maximum effect of the zero-tracking device expressed as fractions of the scale interval.



### 14.3. Scale calibration CAL

For the calibration of the scale, it is recommended to use a standard weight.

CAL 1b

Calibration procedure using a known weight (automatically sets the initial zero and the slope value).

G-SEt

Gravity adjustment depending on the scale's geographical location:

G-COr

ON / OFF correction (activates/deactivates automatic correction according to geographical location).

GEO

Geographical location code (see attached table).

OFSEt

Manual input (keypad) of the initial zero (A/DC counts value).

SPAn

Manual input of the span slope, 5 digits. The divisor needed to transform A/D converter counts to the measurement unit.

PrCAL

Prints a ticket with the configuration and calibration settings in the device's memory.

### 14.4. Scale calibration procedure CAL 1b

1. With the platform free of any load, select the "CAL 1b" option.
2. The display will show that the initial zero value is in progress with the blinking message "CAL 0".
3. Once the zero value has been calibrated, place the calibration weight (a known mass weight) on the load receptor.
4. Enter the weight value in the indicator, including the decimal positions. Use the cursor movement keys to move through the different positions on the display.

5. Once you enter the weight value, double-press on the  $\downarrow$  key to validate and move to next step. The display will show the blinking message “-CAL-” while acquiring the calibration value.
6. Lastly, it will show the message “CE0” for a few seconds, asking for the code of the geographical location where you did the calibration. The geographical location code is a value from 0 to 31, which you have to choose from the attached table. Use the  $\leftarrow$  and  $\rightarrow$  keys to change the value and validate by pressing on the  $\downarrow$  key.
7. Lastly, the message “SAVE” will briefly appear, indicating that the calibration has been saved in the non-volatile memory. The indicator returns to normal use mode, displaying the weight on the load receptor.

The geographical area where the scale is used can be modified later whenever you wish by entering the menu with  $MENU \rightarrow SCALE \rightarrow CAL \rightarrow C-SET \rightarrow CE0 \rightarrow C_{nn}$  (for  $nn \in \{0-31\}$ ).

The automatic correction of the scale calibration according to geographical area can be disabled by entering the menu with  $MENU \rightarrow SCALE \rightarrow CAL \rightarrow C-SET \rightarrow C-Cor \rightarrow OFF$ .

# 16.3 Table of geographical adjustment values

Geographical latitude in the northern or southern hemisphere in degrees and minutes.	Elevation above sea level in metres										
	0	325	650	975	1300	1625	1950	2275	2600	2925	3250
	325	650	975	1300	1625	1950	2275	2600	2925	3250	3575
	Elevation above sea level in feet										
	0	1060	2130	3200	4260	5330	6400	7460	8530	9600	10660
	1060	2130	3200	4260	5330	6400	7460	8530	9600	10660	11730
00°00' - 05°46'	5	4	4	3	3	2	2	1	1	0	0
05°46' - 09°52'	5	5	4	4	3	3	2	2	1	1	0
09°52' - 12°44'	6	5	5	4	4	3	3	2	2	1	1
12°44' - 15°06'	6	6	5	5	4	4	3	3	2	2	1
15°06' - 17°10'	7	6	6	5	5	4	4	3	3	2	2
17°10' - 19°02'	7	7	6	6	5	5	4	4	3	3	2
19°02' - 20°45'	8	7	7	6	6	5	5	4	4	3	3
20°45' - 22°22'	8	8	7	7	6	6	5	5	4	4	3
22°22' - 23°54'	9	8	8	7	7	6	6	5	5	4	4
23°54' - 25°21'	9	9	8	8	7	7	6	6	5	5	4
25°21' - 26°45'	10	9	9	8	8	7	7	6	6	5	5
26°45' - 28°06'	10	10	9	9	8	8	7	7	6	6	5
28°06' - 29°25'	11	10	10	9	9	8	8	7	7	6	6
29°25' - 30°41'	11	11	10	10	9	9	8	8	7	7	6
30°41' - 31°56'	12	11	11	10	10	9	9	8	8	7	7
31°56' - 33°09'	12	12	11	11	10	10	9	9	8	8	7
33°09' - 34°21'	13	12	12	11	11	10	10	9	9	8	8
34°21' - 35°31'	13	13	12	12	11	11	10	10	9	9	8
35°31' - 36°41'	14	13	13	12	12	11	11	10	10	9	9
36°41' - 37°50'	14	14	13	13	12	12	11	11	10	10	9
37°50' - 38°58'	15	14	14	13	13	12	12	11	11	10	10
38°58' - 40°05'	15	15	14	14	13	13	12	12	11	11	10
40°05' - 41°12'	16	15	15	14	14	13	13	12	12	11	11
41°12' - 42°19'	16	16	15	15	14	14	13	13	12	12	11
42°19' - 43°26'	17	16	16	15	15	14	14	13	13	12	12
43°26' - 44°32'	17	17	16	16	15	15	14	14	13	13	12
44°32' - 45°38'	18	17	17	16	16	15	15	14	14	13	13
45°38' - 46°45'	18	18	17	17	16	16	15	15	14	14	13
46°45' - 47°51'	19	18	18	17	17	16	16	15	15	14	14
47°51' - 48°58'	19	19	18	18	17	17	16	16	15	15	14
48°58' - 50°06'	20	19	19	18	18	17	17	16	16	15	15
50°06' - 51°13'	20	20	19	19	18	18	17	17	16	16	15
51°13' - 52°22'	21	20	20	19	19	18	18	17	17	16	16
52°22' - 53°31'	21	21	20	20	19	19	18	18	17	17	16
53°31' - 54°41'	22	21	21	20	20	19	19	18	18	17	17
54°41' - 55°52'	22	22	21	21	20	20	19	19	18	18	17
55°52' - 57°04'	23	22	22	21	21	20	20	19	19	18	18
57°04' - 58°17'	23	23	22	22	21	21	20	20	19	19	18
58°17' - 59°32'	24	23	23	22	22	21	21	20	20	19	19
59°32' - 60°49'	24	24	23	23	22	22	21	21	20	20	19
60°49' - 62°09'	25	24	24	23	23	22	22	21	21	20	20
62°09' - 63°30'	25	25	24	24	23	23	22	22	21	21	20
63°30' - 64°55'	26	25	25	24	24	23	23	22	22	21	21
64°55' - 66°24'	26	26	25	25	24	24	23	23	22	22	21
66°24' - 67°57'	27	26	26	25	25	24	24	23	23	22	22
67°57' - 69°35'	27	27	26	26	25	25	24	24	23	23	22
69°35' - 71°21'	28	27	27	26	26	25	25	24	24	23	23
71°21' - 73°16'	28	28	27	27	26	26	25	25	24	24	23
73°16' - 75°24'	29	28	28	27	27	26	26	25	25	24	24
75°24' - 77°52'	29	29	28	28	27	27	26	26	25	25	24
77°52' - 80°56'	30	29	29	28	28	27	27	26	26	25	25
80°56' - 85°45'	30	30	29	29	28	28	27	27	26	26	25
85°45' - 90°00'	31	30	30	29	29	28	28	27	27	26	26

## 15. FILTERING SETTINGS FILT

Filtering options allow the scale to be configured for use in harsh environments or for weighing moving products, such as liquid tanks or live animals.

LEVEL

Possible values are from **1** up to **7**. A smaller filter level value implies that rapid oscillations in the weight become more visible and vice versa. Default value is level **2**.

LIVES

Additional filter for weighing live animals or people that, when moving on the load receptor, cause oscillations in the weight indication by exerting a variable force on the load cells.

NOE-F

When sets to ON, the indicator doesn't show intermediate weight values when loading / unloading the scale. The result is that the indicator retains the last stable value until the acquisition of a new stable or zero weight.

HSPEED

A/D converter sampling speed. 12 sps / 50 sps (samples per second). A higher sample rate per second will result in faster weight acquisition but will also show short spikes due to a blow or draft.

O-RATE

Output rate for sending data from the Xtrem scale to the K3X terminal in milliseconds. Enter the value in milliseconds. Default value is 50 ms.

## 16. DIGITAL OUTPUTS CONFIGURATION

d Out

This section allows the configuration of the optional 3-relay board available for the **K3X** terminal.

These 3 relay outputs can be used either for controlling an external signalling of the high/low/ok limits in the operation mode as a checkweigher (H-L mode) or for dosing a product. Moreover, it is possible to select whether the dosing is performed for filling a receptacle on the scale (loading) or for emptying a receptacle (unloading). The options in this section of the menu are the following:

mode

Operation mode for controlling the optional relay board.

check ●

The relay outputs will be controlled by the H-L operation mode. The K1 relay closes when the weight on the scale is greater than the limit h Lgh. The K2 relay closes when the weight is between the Lgh and h Lgh limits. The K3 relay closes when the weight is below the Lgh value.

dosing

The relay outputs will be controlled by the dosing mode.

test

Allows each one of the 3 relays to be test and operated by the user.

h-L

Setting the upper and lower values for running the “checkweigher” mode.

Lgh

Value of the lower limit, including the decimal part.

h Lgh

Value for the upper limit, including the decimal part.

act on

Yes / No: Activating the limits control when switching on the unit. The H-L key activates or deactivates the limits control.

<code>DO5 1</code>	Setting of values for dosing operation.
<code>SPEED 1</code>	Weight set point for speed 1.
<code>SPEED 2</code>	Weight set point for speed 2.
<code>TYPE</code>	Type of dosing. Loading ( <code>LOAD</code> ) or unloading ( <code>UNLOAD</code> ).
<code>ACT U</code>	Yes / No: Activating the dosage mode when switching on the unit.

## 17. TECHNICAL SPECS

### User interface

Main indicator	6-digit LCD 25.4 mm in height and weight limits visualizer.
Backlit	3-LED (RGB) backlit panel
Keypad	11-key keypad
Acoustic warning	Piezoelectric intermittent-sound mini-buzzer (2300±300 Hz y 85 dB)

### Real time clock

RTC	Date and time (hours, minutes, seconds). Battery backup using a CR2032 3V
-----	------------------------------------------------------------------------------

### Serial RS232C output (K3X and K3iX models)

RS232 port (not available in K3iXP model)	Transmission-only RS-232C.
Transmission speed	9600, 19200, 38400, 57600, 115200
Format	8 bits, no parity, 1 bit stop

### Optional board

3-relay board	Intended for dosing and checkweigher functions.  3 x Relay 5Vdc / Max current 15A / 360W Switching voltage (max.) 28Vdc / 250Vac
---------------	-------------------------------------------------------------------------------------------------------------------------------------------

## Power

Connection to the mains	AC/DC adaptor: Input 100-240Vac, 50-60Hz, 0,6A Output 12Vdc -1 A
Battery	6V-5AH; Service time 25/60 hours depending on use.

## Operating conditions and mechanical data

Operational temperature range	-10°C/+40°C
Size (mm)	<b>K3X 220 x 180 x 83 mm</b> <b>K3iX 225 x 195 x 111 mm</b> <b>K3iXP 225 x 195 x 121 mm</b>
Weight (including battery)	<b>K3X 1,7 kg</b> <b>K3iX 2,5 kg</b> <b>K3iXP 2,8 kg</b>
Assembly	Desktop Optional: Swivel mount wall/column
Tightness	IP-65 (K3X); IP-67 (K3iX)

## Thermal printer (K3iXP model)

Printer life	6000000 printed lines
Resolution	8 dots/mm
Print speed	30 mm/sec
Paper type	Thermal paper reel (57mm wide, 30 mm $\varnothing$ )
Print width	48 mm
Print sizes	6x8 points, 8x16 points, 12x24 points



## 18. CONNECTIONS

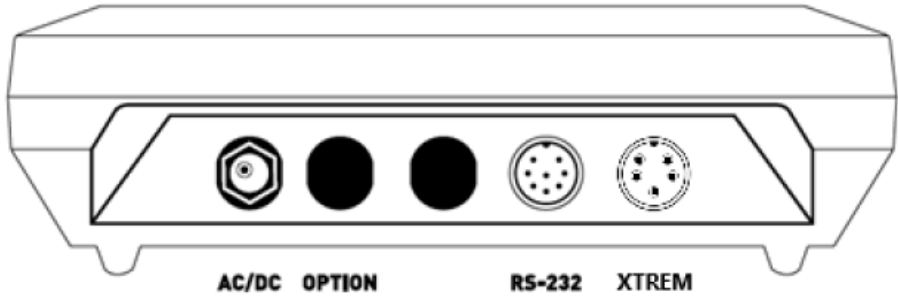

### RS-232 serial output

PIN No.	SIGNAL
PIN 4	RxD
PIN 5	TxD
PIN 6	GND

**NOTE:** Not present in K3iXP model.

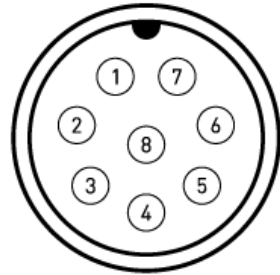

5 MULTI-PIN MOBILE MALE  
(P700) 8 PINES

### XTREM scale connector

PIN No.	SIGNAL
PIN 1	+Vcc
PIN 2	TxD
PIN 3	RxD
PIN 4	Not connected
PIN 5	GND

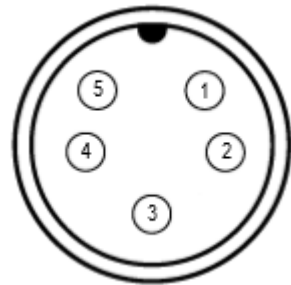

6 MULTI-PIN MOBILE MALE (P700)  
5 PINES

## 19. ERROR MESSAGES

ErrAdC	A/D default: No response from the A/D converter.	Xtrem ADPD module damaged.
AdC H	Load cell input signal too high (>20mV).	Check the scale for some load cell / wiring default.
AdC L	Load cell input signal too low (<-20mV).	
Err 03	Load cell input signal out of range (>30mV)	
ErrP0B	Load cell excitation and A/D converter switched off because a short-circuit.	Check wiring and load cells.
Err 06		
ErrE2P	Data flash memory storage is corrupted and cannot be reset to the factory defaults.	Break the verification seal to open the XTREM cover, set to “unlock” the sealing switch. The instrument must be adjusted and verified / calibrated again.
Err n	Calibration weight > Max.	Adjust weight should be < Max.
Err d	The division should be >10 A/D counts.	Resolution is too high. Change the division to a higher value.
Err C	A stable measurement cannot be obtained for adjusting the scale.	Increase the filter level.
-0 L-	Overload: Weight > Max+9·div	
Pr0t	Settings value cannot be changed because the “sealing switch” is at lock position.	Legally relevant settings cannot be changed without breaking the verification seal.
-----	Negative weight (weight < -19e)	
-00-	Initial zero setting in progress	
ErrC0n	Communication error	Check baud rate setup





**Gram Precision S.L.**

Travesía Industrial, 11 · 08907 Hospitalet de Llobregat · Barcelona (Spain)

Tel. +34 902 208 000 · +34 93 300 33 32

Fax +34 93 300 66 98

[comercial@gram.es](mailto:comercial@gram.es)

[www.gram-group.com](http://www.gram-group.com)